



# CAN AM

## PRECAST PRODUCTS LTD.

### 2000 Gallon Septic Tank

DIMENSIONS: 178 1/2" X 97 1/2" X 52 1/2" High  
WEIGHT: 7.6 TON TANK/3 TON LID

#### 3 DIMENSIONAL VIEW

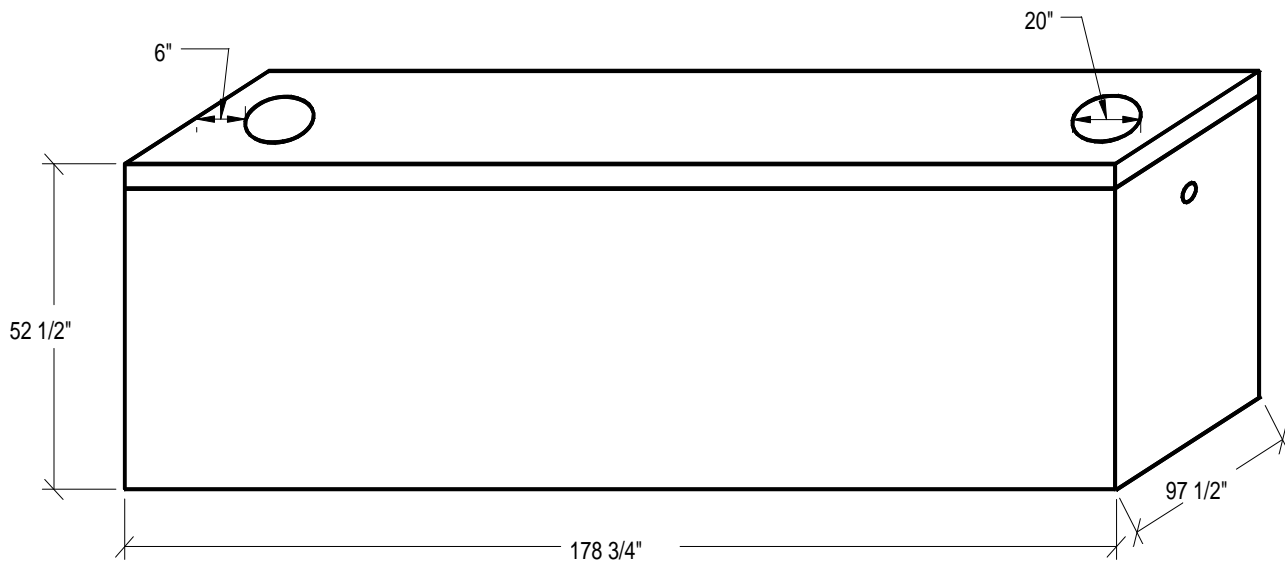

#### SIDE VIEW

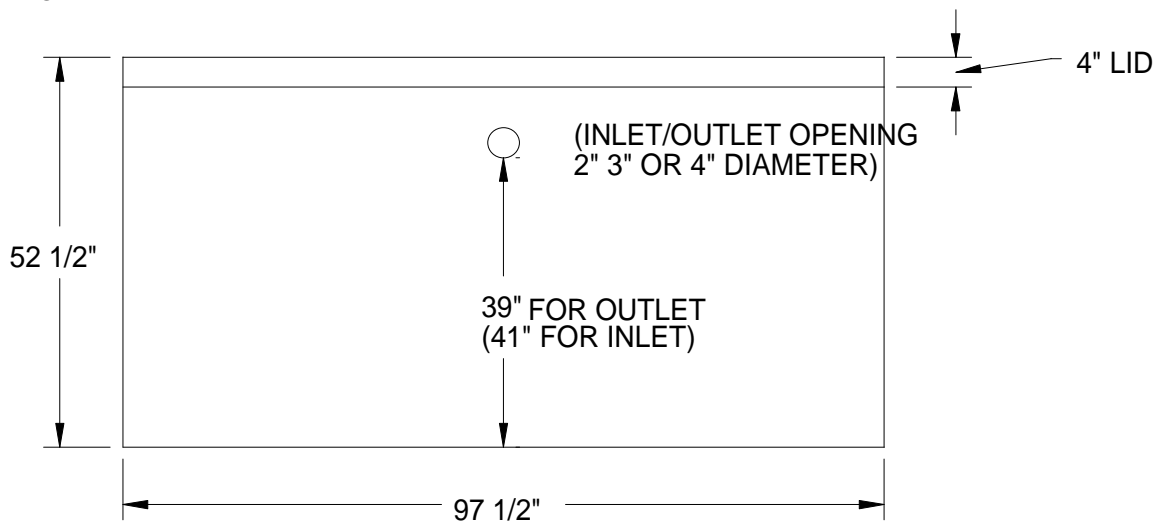

[www.canamprecast.com](http://www.canamprecast.com)